



VW FUN CUP

ANNEXE III - REVISION 1

ADDITIF 1

REMARQUE IMPORTANTE : TOUS LES ELEMENTS DE CET ADDITIF SONT OPTIONNELS
IMPORTANT COMMENT : ALL ELEMENTS OF THIS ADDITIVE ARE OPTIONAL

A) Voiture vue de 3/4 avant
Car seen from 3/4 front



B) Voiture vue de 3/4 arrière
Car seen 3/4 rear



1. GENERALITES / GENERAL

101. Constructeur
Manufacturer **W RACING TEAM**

102. Dénomination commerciale
Commercial name **FUN CUP EVO 3**

5. EQUIPEMENT ELECTRIQUE / ELECTRICAL EQUIPMENT

Rampe de phares
Headlamp ramp

A01-1) Rampe de phares montée
Headlamp ramp mounted

A01-2) Phares latéraux
Side headlamp

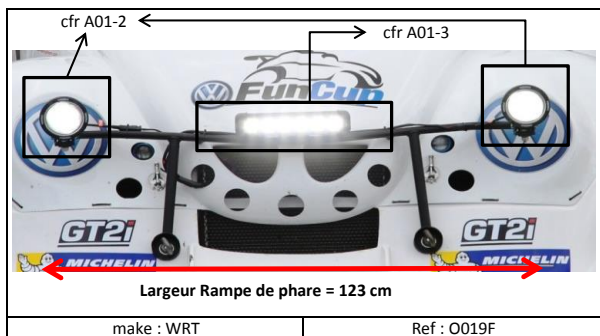

A01-3) Barre de phares centrale (6 x 10W)
Central lightbar (6 x 10W)





VW FUN CUP

ANNEXE III - REVISION 1

ADDITIF 1

REMARQUE IMPORTANTE : TOUS LES ELEMENTS DE CET ADDITIF SONT OPTIONNELS
IMPORTANT COMMENT : ALL ELEMENTS OF THIS ADDITIVE ARE OPTIONAL

6. TRANSMISSION / POWER TRAIN

Refroidissement boîte de vitesse
Gear box cooling

A01-4) Système de refroidissement complet démonté
Complete cooling system dismantled

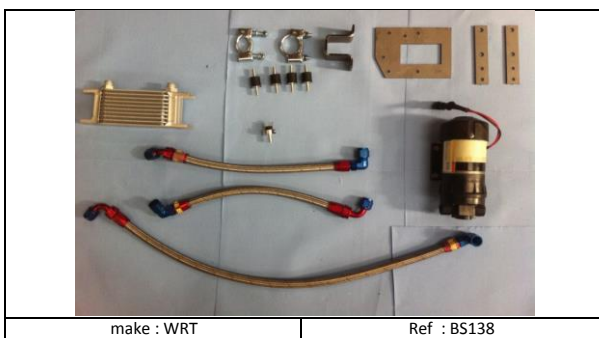

A01-5) Radiateur
Radiator



A01-6) Pompe
Pump



A01-7) Système de refroidissement complet monté
Compleat cooling system mounted





VW FUN CUP

ANNEXE III - REVISION 1

ADDITIF 1

REMARQUE IMPORTANTE : TOUS LES ELEMENTS DE CET ADDITIF SONT OPTIONNELS
IMPORTANT COMMENT : ALL ELEMENTS OF THIS ADDITIVE ARE OPTIONAL

Changement de vitesse au volant Paddle shift

A01-8) Système complet démonté
Complete system dismantled

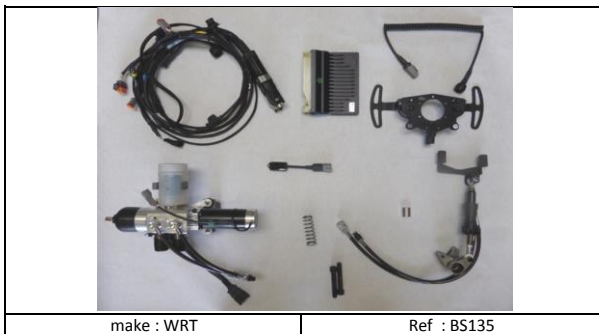

A01-9) Palettes au volant
Paddle shift



A01-10) Moteur paddle shift et réservoir montés
Paddle shift motor and oil tank



A01-11) verrin monté
cylinder mounted



A01-12) Boîtier paddle shift monté
ECU paddle shift mounted

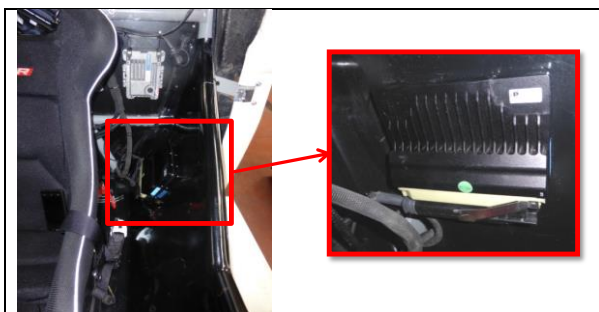



VW FUN CUP

ANNEXE III - REVISION 1

ADDITIF 1

REMARQUE IMPORTANTE : TOUS LES ELEMENTS DE CET ADDITIF SONT OPTIONNELS
IMPORTANT COMMENT : ALL ELEMENTS OF THIS ADDITIVE ARE OPTIONAL

8. TRAIN ROULANT / RUNNING GEAR

Roues
Wheels



'Version française'
'French version''

- a) Marque et type
Make and type
- b) Diamètre
Diameter
- c) Largeur / ET
Width / ET
- d) Matériau
Material
- e) Poids minimum
Minimum weight

	Avant/front	Arrière / rear
a) Marque et type Make and type	<u>TEAM DYNAMICS MOTORSPORT</u>	<u>Idem Annexe 3</u>
b) Diamètre Diameter	<u>15</u> pouces / inches	-
c) Largeur / ET Width / ET	<u>7</u> pouces / inches / 36	-
d) Matériau Material	<u>Aluminium Alloy</u>	-
e) Poids minimum Minimum weight	<u>6,9 kg</u>	-
		-

'Version tôle'
'Steel version''

- a) Marque et type
Make and type
- b) Diamètre
Diameter
- c) Largeur
Width
- d) Matériau
Material
- e) Poids minimum
Minimum weight

	Avant/front	Arrière / rear
a) Marque et type Make and type	<u>TBA</u>	<u>TBA</u>
b) Diamètre Diameter	<u>15</u> pouces / inches	<u>15</u> pouces / inches
c) Largeur Width	<u>7</u> pouces / inches	<u>8</u> pouces / inches
d) Matériau Material	<u>Steel</u>	<u>Steel</u>
e) Poids minimum Minimum weight	<u>12,0 kg</u>	<u>12,6 kg</u>
		



VW FUN CUP

ANNEXE III - REVISION 1

ADDITIF 1

REMARQUE IMPORTANTE : TOUS LES ELEMENTS DE CET ADDITIF SONT OPTIONNELS
IMPORTANT COMMENT : ALL ELEMENTS OF THIS ADDITIVE ARE OPTIONAL

**Direction
Steering**

- a) Type
Type
- b) Servo-assistance
Power assisted
- c) Type d'assistance
Power assisted type
- d) Emplacement moteur
Power assisted location
- e) Emplacement de l'ECU direction
ECU steering location

AVANT/FRONT	ARRIERE/REAR						
RACK & PINION	NA						
<table border="1" style="margin: auto;"> <tr> <td style="text-align: center;">✕</td> <td style="text-align: center;">oui</td> <td style="text-align: center;">non</td> </tr> <tr> <td></td> <td style="text-align: center;">yes</td> <td style="text-align: center;">non</td> </tr> </table>	✕	oui	non		yes	non	NA
✕	oui	non					
	yes	non					
Electric	NA						
On steering column	NA						
see pictures	NA						

A01-13) Direction assistée démontée (avec axe monoplace)
Power assisted steering dismantled (with monoplace shaft)

A01-14) ECU et boîtier de réglage démontés
ECU and adjusting box dismantled

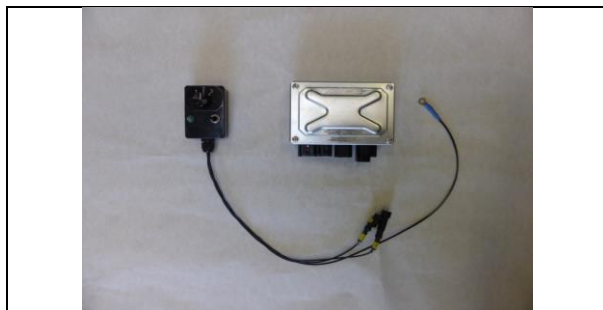
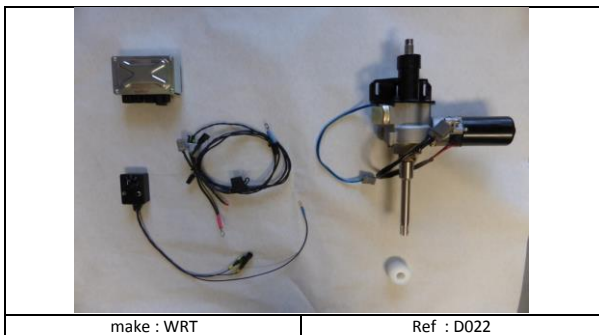

A01-15) Axe monoplace (L=170 mm)
Monoplace shaft (L=170 mm)

A01-16) Axe biplace (L=190 mm)
Biplace shaft (L=190 mm)

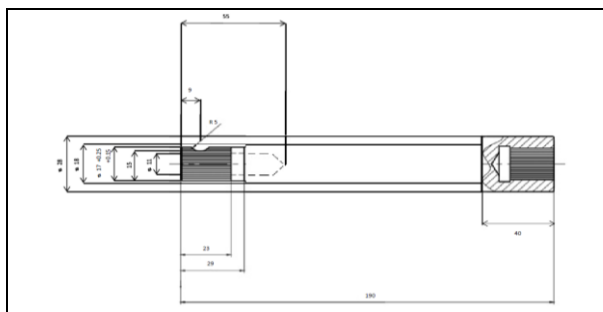
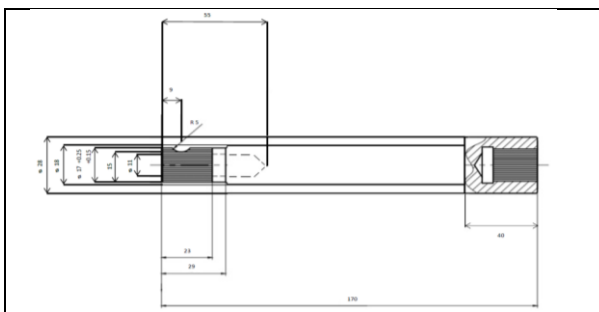



VW FUN CUP

ANNEXE III - REVISION 1

ADDITIF 1

REMARQUE IMPORTANTE : TOUS LES ELEMENTS DE CET ADDITIF SONT OPTIONNELS
IMPORTANT COMMENT : ALL ELEMENTS OF THIS ADDITIVE ARE OPTIONAL

A01-17) ECU monté
ECU mounted

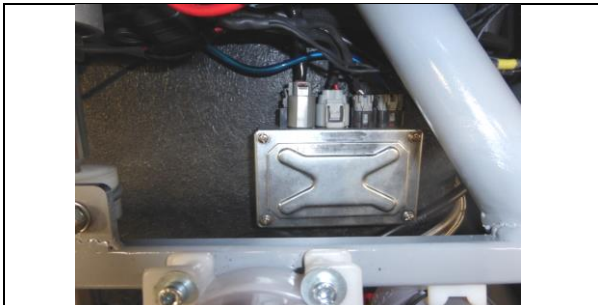

A01-18) Boîtier de réglage monté
Adjusting box mounted



A01-19) Direction assistée montée
Power assisted steering mounted

